

# FALC

## Mod. MASTER

TRINCIA LATERALE e POSTERIORE - BROYEUR D'ACCOTEMENT  
LATERAL and REAR SHREDDER - SEITEN und HINTERER HÄCKSLER  
DESBROZADORA LATERAL y POSTERIOR - ИЗМЕЛЬЧИТЕЛИ БОКОВЫЕ и ЗАДНИЕ



Trincia laterale professionale, per erba, cespugli, rovi in frutteti, agrumeti, uliveti e per la manutenzione di bordi stradali

Broyeur Latéral professionnel, pour herbes, buissons, ronces dans les vergers, les plantations d'agrumes, d'olives et pour l'entretien des routes

Professional Lateral Shredder for grass, bushes and brambles in orchards, citrus groves, olive groves and for roadside maintenance

Profi Seitenhäcksler, zum Häckseln von Gras, Gebuschen in den Obstgarten, Olivengarten und Wartung am Straßenrand

Desbrozadora lateral profesional, para hierba, matas y zarzas en fincas, cítricos, olivares y para el mantenimiento a lo largo de carreteras

Профессиональный боковой измельчитель для травы, кустов в садах, цитрусовых, оливковых рощах и для ухода за дорогами







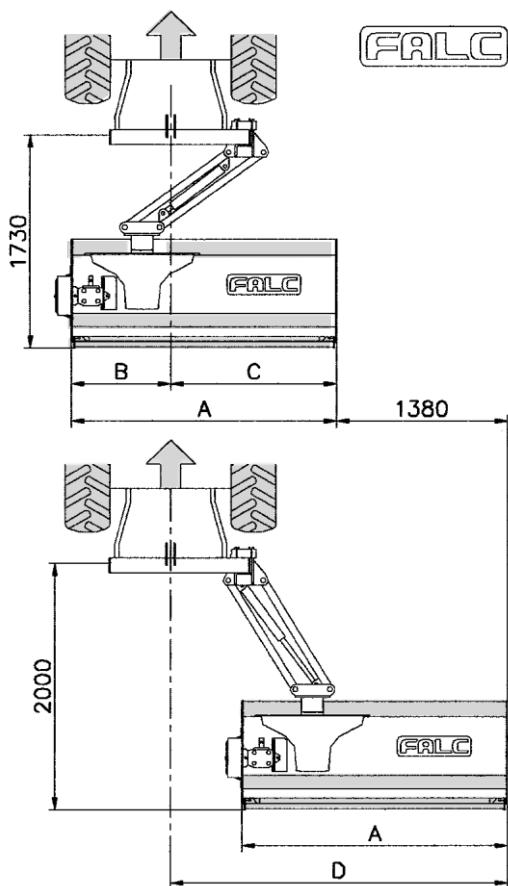

# Mod. MASTER









80-120 HP

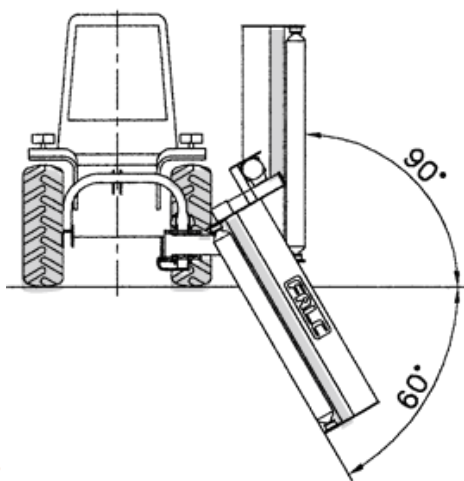
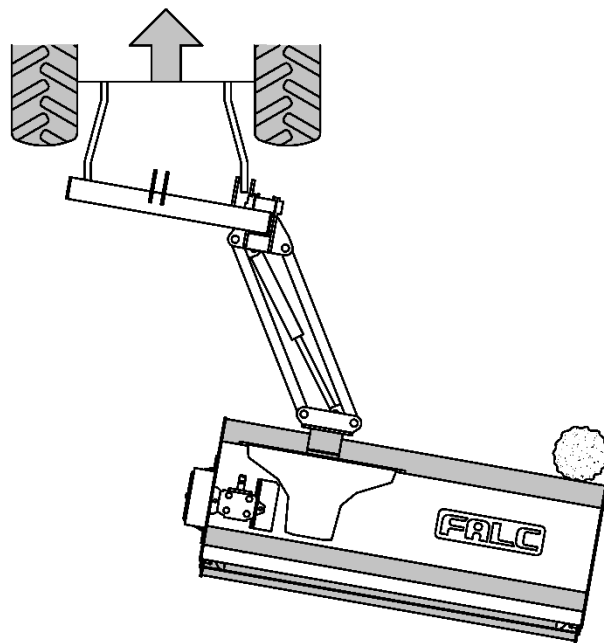

| MASTER | A    | B   | C    | D    |
|--------|------|-----|------|------|
| 1600   | 1600 | 800 | 800  | 2180 |
| 1800   | 1780 | 800 | 980  | 2360 |
| 2100   | 2140 | 800 | 1340 | 2720 |

-  In presenza di ostacoli un sistema di sicurezza garantisce l'arretramento del trincia, con ritorno automatico.
-  En cas d'obstacles un dispositif de sécurité permet le recul du groupe de broyage et son retour automatique.
-  If an obstacle is contacted, a safety system allows the shredder to pivot clear then automatically reset.
-  Bei Hindernissen gewährt die automatische Sicherung das Ausweichen und das automatische Zurückstellen des Häckslers.
-  En presencia de obstáculos, un aparato de seguridad garantiza el retroceso de la desbrozadora con retorno automático.
-  При появлении преграды система безопасности автоматически втягивает фрезу и возвращает обратно при объезде преграды.



-  **Avvertenza:** la trattrice deve essere dotata di 2 prese d'olio a doppio effetto.
-  **Attention:** le tracteur doit être équipé avec 2 prises d'huile à double effet.
-  **Attention:** the tractor must be equipped with 2 double effect oil plugs.
-  **Achtung:** Schlepper muss mit 2 Doppel Öableitung ausgerüstet sein.
-  **Advertencia:** el tractor deberá poseer 2 tomas de aceite de doble efecto.
-  **Внимание:** трактор должен иметь два выхода гидравлики.



| MASTER |     |      |       |       |          |          |    |          |     |    |
|--------|-----|------|-------|-------|----------|----------|----|----------|-----|----|
|        | Kg. | LBS  | A mm. | B mm. | A inches | B inches | N. | HP.      | PTO | N. |
| 1600   | 790 | 1742 | 1585  | 1746  | 62,40    | 68,74    | 16 | 80 - 120 | 540 | 4  |
| 1800   | 850 | 1874 | 1765  | 1926  | 69,48    | 75,82    | 18 | 80 - 120 | 540 | 4  |
| 2100   | 920 | 2028 | 2125  | 2286  | 83,66    | 90,00    | 22 | 80 - 120 | 540 | 4  |

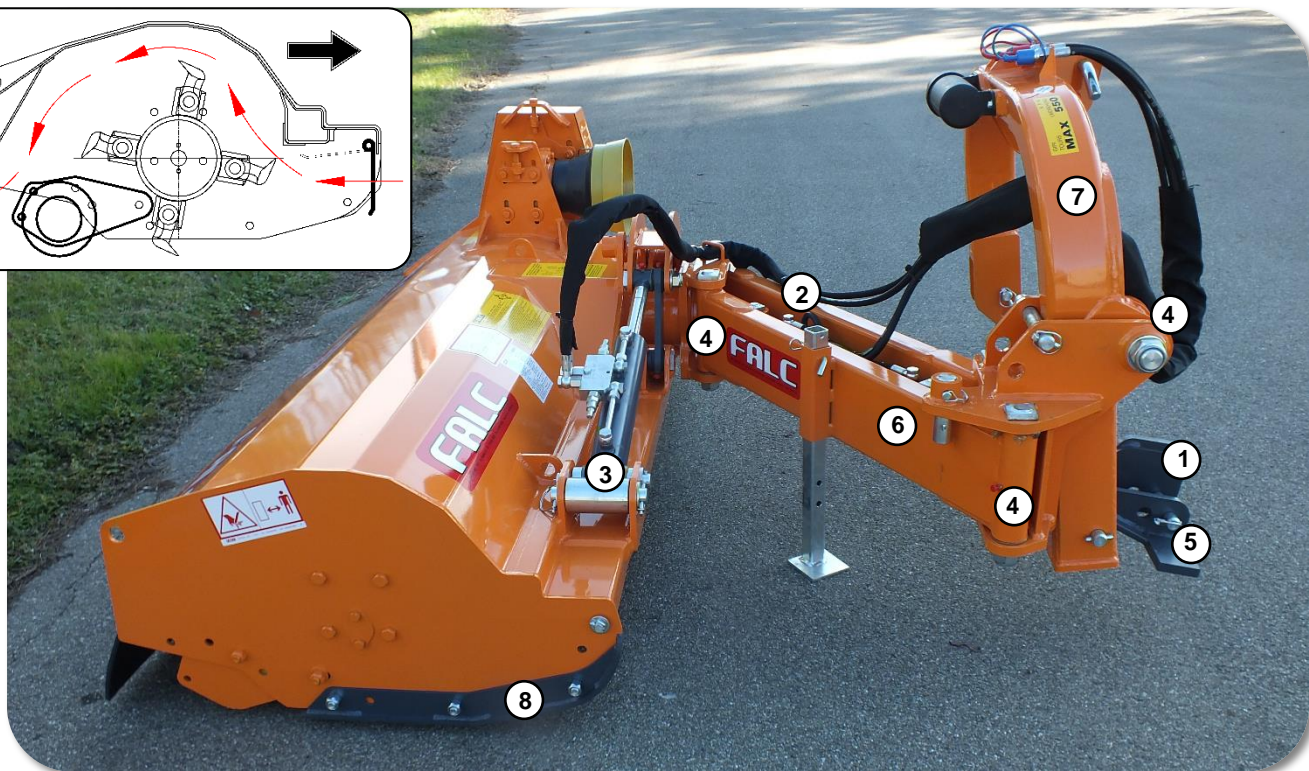
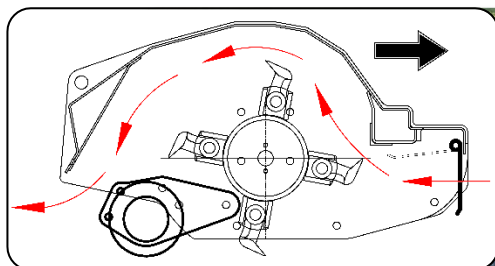

1. Ammortizzatore meccanico
2. e 3. Martinetti per spostamento laterale e per inclinazione di grandi dimensioni
4. Punto di snodo; tutti gli snodi sono su boccole autolubrificanti
5. Nessun perno è a sbalzo
6. Bracci di spostamento 180 x 60
7. Attacco 3° punto 120 x 80
8. Slitte arrotondate



1. Amortisseur mécanique
2. et 3. Vérins de déport latéral et déversement de grandes dimensions
4. Point d' articulation: toutes les articulations sont sur de bagues autolubrifiants
5. Tous les pivots sont sur 2 supports
6. Bras de déplacement 180 x 60
7. Attelage 3em point 120 x 80
8. Patins arrondis



1. Mechanic shock absorber
2. and 3. Big Jacks for lateral shifting and inclination
4. Pivoting point; all joints run on self-lubricating bushes
5. All the pins have 2 supports
6. Shifting arms 180 x 60
7. 3<sup>rd</sup> point headstock 120 x 80
8. Round skids



1. Mechanischer Stoßdämpfer
2. und 3. Grosse Zylinder für seitliche Verschiebung und Neigung
4. Gelenk; alle Gelenke laufen auf Büchse mit Selbsttätigen Schmierung
5. Alle Bolzen haben 2 Halter
6. Verschiebungsarmen 180 x 60
7. 3 Punkt Anbaubock 120 x 80
8. Gerundete Kufen



1. Amortiguador mecánico
2. y 3. Pistones de desplazamiento lateral y inclinación de grandes dimensiones
4. Punto de desarticulación: todas las articulaciones son sobre casquillos autolubricantes
5. Todos los pivotes están sobre dos soportes
6. Brazos de desplazamiento 180 x 60
7. Eganche 3° punto 120 x 80
8. Patines en forma arqueada



1. Механический амортизатор
2. и 3. Молоточки для бокового смещения и для наклона
4. Точка поворота, все соединения на самосмазывающихся втулках
5. Никакой штифт не консольный; все штифты на 2 опорах
6. Переносные 180 x 60
7. 3-х точечные рычаги 120 x 80
8. Лыжами округлый



- 9. Tuborotore: Ø mm 194
- 10. Tuborullo posteriore: Ø mm 168
- 9. Tuberotor: Ø mm 194
- 10. Tuberoleau arrière: Ø mm 168
- 9. Rotor tube: Ø mm 194
- 10. Rear roller's tube: Ø mm 168
- 9. Rohr für Rotor: Ø mm 194
- 10. Rohr für Hinteren Walze: Ø mm 168
- 9. Tuborotor: Ø mm 194
- 10. Tuborodillo trasero: Ø mm 168
- 9. Трубаротора: Ø 194 mm
- 10. Труба заднего катка: Ø 168 mm

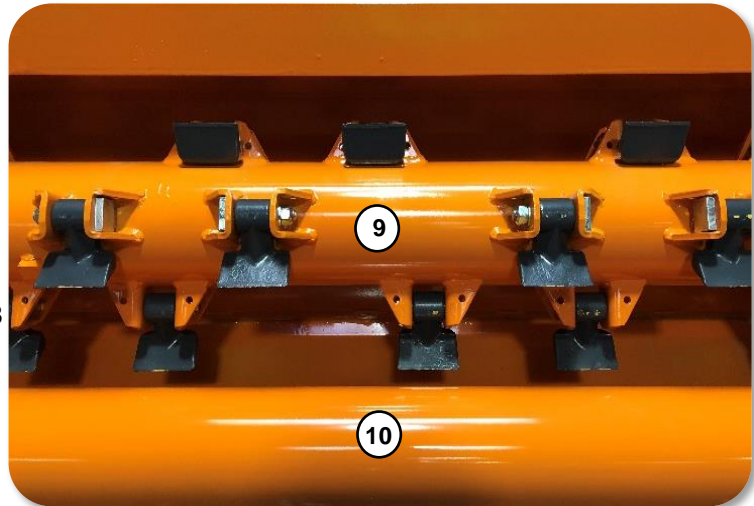

- OPZIONE
- OPTION
- OPTION
- OPTION
- OPCIÓN
- ОПЦИЯ

- 11. Rotore con coltelli TLF
- 11. Rotor mit TLF Messern
- 11. Rotor avec couteaux TLF
- 11. Rotor con cuchillas TLF
- 11. Rotor with TLF blades
- 11. Ротор с ножами "TLF"

|                                 |             |          |
|---------------------------------|-------------|----------|
| Peso minimo trattore per:       | MASTER 1600 | Kg. 3000 |
| Poids minimum tracteur:         |             |          |
| Minimum weight of tractor:      | MASTER 1800 | Kg. 3500 |
| Minimum Gewicht des Schleppers: |             |          |
| Peso mínimo tractor:            | MASTER 2100 | Kg. 4000 |
| Минимальная масса трактора:     |             |          |

|                                |             |         |
|--------------------------------|-------------|---------|
| Larghezza minima trattore per: | MASTER 1600 | mm 1700 |
| Largeur minimum tracteur:      |             |         |
| Minimum width of tractor:      | MASTER 1800 | mm 1900 |
| Minimum Breite des Schleppers: |             |         |
| Ancho mínimo tractor:          | MASTER 2100 | mm 2200 |
| Минимальная ширина трактора:   |             |         |

